

SONICATOR[®]
3000
ULTRASONIC LIQUID PROCESSOR

OPERATION MANUAL



1938 New Highway, Farmingdale, NY 11735 U.S.A.
Telephone: 631-694-9555 Fax: 631-694-9412
Toll Free: 1-800-645-9846
www.misonix.com

TABLE OF CONTENTS

1.	Safety - Warnings and Precautions	1-1
2.	Getting Started	2-1
	Inspection	2-1
	Power Requirements	2-1
	Placement of Equipment	2-1
3.	Specifications for S3000	3-1
4.	Description of Major Components	4-1
	Generator (Power Supply)	4-1
	Process Control Features of Model S3000	4-1
	Convertor (Transducer)	4-1
	Horn (Probe)	4-1
	Replacement Flat Tips	4-2
5.	Description of Controls and Connectors	5-1
	Front Panel Description	5-1
	Rear panel Description	5-2
6.	Preparation for Use	6-1
	Convertor Mounting Diagram	6-2
	Attachment and Removal of Horns and Tips	6-3
	Attachment and Removal of Horns and Tips Diagram	6-4
7.	S3000 Operating Instructions	7-1
	Review of Keys	7-1
	Programming the Unit	7-2 to 7-6
8.	Accessories	8-1
	Cup Horn	8-1 to 8-3
	Flocell™	8-3 to 8-4
	Microtip™	8-5
	Stepped Microtip™	8-5
	Extender Tip	8-6
	Sapphire Tipped Horn	8-6
	Sonabox™	8-7
	Dual Horn	8-7
	Microplate Horn	8-7
	Sonabox™ Diagram	8-8
9.	Troubleshooting	9-1
	Overload Indicator Instructions	9-1
	Troubleshooting Guide	9-1
10.	Maintenance	10-1
	General Maintenance	10-1
	Cleaning Instructions	10-1

	Tip Care	10-2
11.	Applications	11-1
	Principle of Ultrasonics	11-1
	Processing Tissue	11-1
	Processing Difficult Cells	11-2
12.	Techniques	12-1
	Probe Depth	12-1
	Foaming and Aerosoling	12-1
	Viscosity Limitations	12-1
	Keeping Samples Cool	12-1
	Free Radical Formation	12-1
13.	Warranty	13-1
14.	Return of Equipment	14-1
15.	Literature Request	15-1
	Published Papers	15-1
	Bibliographies	15-1
	Application Notes	15-1
	Technical Notes	15-2
	Technical Bulletins	15-2

1. SAFETY - WARNINGS AND PRECAUTIONS

Read ALL Instructions Before Installing or Using Equipment

Your new Ultrasonic Liquid Processor has been designed, built and tested to assure maximum operator safety. However, no design can completely protect against improper use that may lead to bodily injury and/or property damage. For total safety and equipment protection, read the instruction manual carefully before attempting to operate this equipment. Observe the following WARNINGS:



- High voltage is present in the generator (power supply), convertor and high frequency cable. There are no user-serviceable parts inside any of these devices. Do NOT attempt to remove the generator cover or convertor case.



- Do NOT touch any open cable connections on the unit while the power is turned ON.
- Do NOT operate generator with convertor disconnected from high voltage cable. High voltage is present in the cable and may pose a shock hazard.
- Do NOT attempt to disconnect the convertor high voltage cable while the unit is Running.
- The generator must be properly grounded with a 3-prong plug. Test electrical outlet for proper grounding before plugging in unit.
- Install the SONICATOR® in an area free from excessive dust, dirt, explosive or corrosive fumes and protected from extremes in temperature and humidity.
- NEVER immerse the convertor in liquids of any kind, or let condensed moisture or liquid drip into the convertor.
- NEVER grasp an activated horn or touch the tip of a vibrating probe. It can cause severe burns and tissue damage.
- NEVER hold or clamp the convertor by the front driver (black portion) or by the horn itself. This can cause permanent damage to the system. Support the convertor by only clamping around the convertor case.
- Do NOT allow the tip of a vibrating horn or probe to touch the counter top or any other hard surface. It could damage the probe, overload the generator, or damage the surface.
- Avoid touching the bottom or sides of a glass or plastic container with an activated probe. It could crack or shatter the glass or melt the plastic.
- Turn OFF the power switch, unplug the generator and disconnect the power cord from the back of the generator before attempting to replace the fuses.

2. **GETTING STARTED**

Inspections

Your new SONICATOR® 3000 Ultrasonic Liquid Processor was thoroughly inspected, tested and carefully packed before leaving the factory. Prior to unpacking, carefully inspect the shipping carton for any evidence of damage. Claims for loss or damage sustained in transit, must be made to the shipping company.

Unpack the unit from its shipping carton and check the contents against the packing list. Before disposing of the packing material, check it carefully for small items. Report any missing components to Misonix immediately.

Visually inspect all external controls, indicators and surfaces to detect any damage in transit. If damage has occurred, contact your carrier within 48 hours of delivery date. **DO NOT OPERATE DAMAGED EQUIPMENT.** Retain all packing materials for possible future shipments.

Power Requirements

For power requirements, check the label on the back of the unit.

1. For 100V operation, the generator requires a single phase, three wire, 100V, 50/60 Hz line supply, unless otherwise specified.
2. For 120V operation, the generator requires a single phase, three wire, 120V, 50/60 Hz line supply, unless otherwise specified.
3. For 220V operation, the generator requires a single phase, three wire, 220V, 50/60 Hz line supply, unless otherwise specified.

WARNING!!

The electrical line cord is equipped with a 3-prong grounding plug. Do not, under any circumstances, remove the grounding prong. The plug must be plugged directly into a mating 3-prong grounding type outlet.

Placement of Equipment

Place the Generator in an area that is free from excessive dust, dirt, water and explosive or corrosive fumes. A fan maintains safe operating temperature in the generator by circulating air over the electronic components. Therefore, the generator must be placed so that the air intake grills on the rear and lower panels are not blocked. DO NOT place unit on a soft surface such as a towel or foam, which may compress and block the lower grill. Place unit on a hard smooth surface only. Clean and inspect the air intake grill periodically, to insure it is free from dust and debris.

3. SPECIFICATIONS FOR S3000

Generator	100 Vac	110 Vac	220 Vac
Input Voltage	90-110 Vac @ 50/60 Hz	100-130 Vac @ 50/60 Hz	200-260 Vac @ 50/60 Hz
Full Load Current	10 Amps	10 Amps	7.5 Amps
Fuse Rating	10 Amps (GDB10)*	10 Amps (GDB10)*	8 Amps (GDB8)*
Weight	14 lbs. (6.3Kg)	14 lbs. (6.3Kg)	16.5 lbs. (7.4Kg)
Dimensions	7.5"W x18.5"L x11.6"H 19cm x 47cm x 29.5cm		
Output Voltage	1500 V rms (max.)		
Output Frequency	20 KHz (nom.)		

Convertor	
Weight	2 lbs. (0.9 Kg)
Dimensions	8" L x 2.5" Dia. (20.3cm x 6.4cm)
Materials	Aluminum

Standard Horn	
Weight	0.5 lbs. (0.45Kg)
Dimensions	5" L x1.5" Dia. (12.7cm x 3.8cm)
Materials	Titanium Alloy

Environmental	
Pollution Degree	Two (2)
Installation Category	II
Temperature Limits	50°F to 110°F (10°C to 43°C)
Barometric Pressure	Unlimited**

* Only use IEC approved fuses, model GDB10 for 100V, 120V and GDB8 for 220V. Do NOT use "slow blow" fuses or fuses rated above the amperage noted. ** In a Vacuum area, additional cooling provisions may be needed.

ACCESSORIES

Use only accessories and probes listed in the Misonix catalog as suitable for operation with this equipment. Do **NOT** attempt to fabricate ultrasonic tooling or accessories as the use of improper equipment can damage the Sonicator® and void the warranty.

4. DESCRIPTION OF MAJOR COMPONENTS

Generator

Includes all operating controls and indicators, detachable three-wire grounded line cord, fuse, external power control jack and high frequency cable connector.

Process Control Feature of the Sonicator® 3000

- **Microprocessor Controller** - allows precise control of output amplitude, elapsed processing time, and cyclical rates during power pulsing. It encompasses the functions of the Digital Integrating Timer and the Multi-Range PULSAR & Cycle Timer.
- **Digital Integrating Timer** - permits precise timing of ultrasonic energy, which can be applied in one-second increments from one-second to 100 hours. The total desired processing time is entered on the keypad. Both the processing time selected and actual total elapsed processing time is indicated by an LCD readout. A start/stop control initiates or reinitiates timed ultrasonic processing. A pause control allows manual pulsing or delay. The total preset time of active ultrasonic processing is unaffected by pauses or pulsing, whether by hand or with the Multi-Range PULSAR & Cycle Timer.
- **Multi-Range PULSAR & Cycle Timer** - permits the application of ultrasonic energy to the sample on a pulsed basis. Pulse on and off times are adjustable in 0.1-second increments from 0.5 seconds to 1 hour each. Pulsed operation permits high intensity sonication while avoiding heat build-up in the sample. It also allows particulate material being processed to settle back under the tip.
- **OVERLOAD INDICATION** - under certain load conditions, the amount of power supplied to the convertor/horn assembly might overload the circuitry of the generator to the point of failure. In order to prevent damage to the generator, an overload protection feature has been built into the unit. When the output power exceeds design specifications, the output power will be disabled. The following prompt will appear: "OVERLOAD! Press CLEAR to RESET". The Power Knob display will flash "888", and the alarm will beep.
- **Temperature Monitoring/Control of Processed Liquids**
The temperature probe can be placed in the liquid being processed to monitor the temperature, to shut down the unit when a programmable maximum temperature is reached, and to activate an external cooling device to cool the liquid being processed. **Note:** Do not allow the temperature probe to come in contact with the Horn or Probe.

Convertor (Transducer)

The convertor is a gray, cylindrical unit (mounting area), and black colored front driver (the first stage of acoustic amplification) with a ½" - 20 threaded hole for horn attachment. A detachable high-frequency cable is also supplied.

Horn (Probe)

A horn is a 5" resonant body that steps down from 1 ½" to a specific diameter tip. The horn serves as the second stage of acoustic amplification. The horn may be solid or have a removable tip and is supplied with a ½" - 20 threaded stud for attachment to the convertor and external threads around the body for attachment of accessories such as a Microtip™. Horns are available in three standard tip diameters of ½", ¾" or 1" and come in three different tip configurations. Tapped horns have a replaceable Flat Tip; Solid horns do not have a replaceable tip; and Sapphire tipped horns have a

1/16" thick sapphire disk bonded to the tip of a solid horn.

Replaceable Flat Tips

Tapped horns have replaceable flat tips, at the radiating surface attached to the end of the horn. The flat tips will erode with use and are replaceable. Tip size matches horn diameter.

S3000 REAR PANEL DESCRIPTION

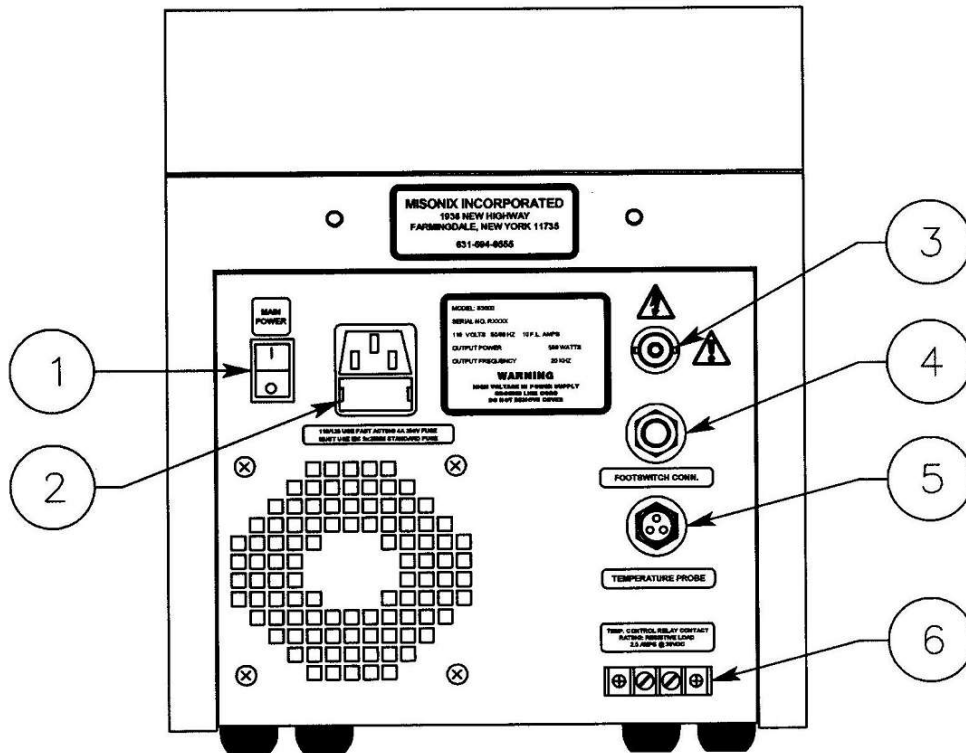

- 1- POWER SWITCH**
- 2- POWER CORD RECEPTACLE**
- 3- CONVERTOR CONNECTOR**
- 4- FOOTSWITCH CONNECTOR**
- 5- TEMPERATURE CONNECTOR**
- 6- EXTERNAL CONTROL DEVICE TERMINAL BLOCK**

6. **PREPARATION FOR USE**

1. To safeguard the fuse against failure, always switch the power supply off before connecting or disconnecting the power cord.
2. Check to make sure that the Power Switch on the generator is turned OFF.
3. Connect the Power Cord to the receptacle on the rear of the generator and plug it into a grounded power outlet.
4. If the Sonicator® has been left in a very cold environment for a prolonged period of time, do not operate the unit until it has reached room temperature. Turn the power switch ON, without processing any samples, for 20 minutes before using, to warm-up the electronics faster.
5. The horn and its flat tip were assembled and attached to the convertor at the factory, but it is recommended that you check the tightness of the horn and flat tip by using the wrenches provided and referring to 6-3 & 6-4 of this manual. An insufficiently tightened horn or tip might cause damage to the generator circuitry or parts of the convertor and horn. **NEVER** assemble or disassemble the probe by holding the convertor in a vise or while power is on. **ALWAYS** use the wrenches supplied with the unit.
6. When replacing horns or horn tips, clean the mating surfaces of the convertor and probe or stepped microtip as well as the threaded stud and hole. Check that the stud is tight. Do **NOT** apply grease to mating surfaces or threads of the convertor, horn, replaceable flat tip or microtip probe.
7. Mount the convertor and horn into the sleeve on the top of the SONABOX™ Acoustic Enclosure (Part # 432B) or use the Convertor Stand and Positioner (Part # 438) to hold the convertor and horn in position. Support the convertor only by clamping around the outer case (See 6-2).
Do **NOT** hold or clamp the convertor, on the black portion or the titanium horn itself.
9. Connect either end of the coaxial HIGH FREQUENCY cable to the rear of the chassis and the other end to the receptacle on the convertor. Push the connectors in and turn the chrome rings clockwise ¼ turn to secure the connectors.
10. If a foot switch or timer switch is used, plug it into the FOOT SWITCH CONNECTOR. Make sure that the plug is inserted properly.
11. If you will be using a MICROTIP or Extender, remove the Flat Tip on the end of the horn, then attach the MICROTIP or Extender in its place. (See 6-3, 6-4)

CONVERTOR MOUNTING DIAGRAM



Correct converter clamping.

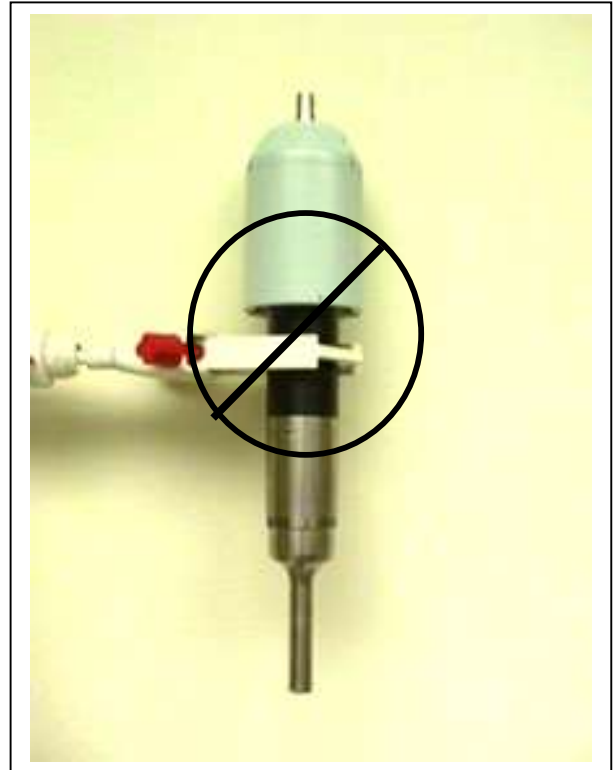

Incorrect converter clamping method.

ATTACHMENT AND REMOVAL OF HORNS AND TIPS

To connect a horn to the convertor or a tip to a horn:

1. Thread pieces together by hand until all joints mate smoothly and are hand tight. If resistance is met, avoid cross threading by loosening and rethreading by hand.
2. Do **NOT** force the threads by wrenching.
3. Tighten using wrenches as explained below, being sure to apply even and firm pressure.

To attach or remove a horn:

1. Insert the pin of the pin spanner wrench supplied with the Sonicator® (as shown in the diagram on **page 6-4**) into one of the holes at the base of the horn.
2. Insert the pin of the second pin spanner wrench into one of the holes in the front driver (black portion) of the convertor.
3. Apply even and firm pressure in the appropriate direction.

To attach or remove a Flat Tip, Microtip or Extender:

1. Insert the pin of a pin spanner wrench into one of the holes at the base of the horn.
2. Place the 7/16" open-end wrench on the wrench flats of the Flat Tip, MICROTIP or Extender.
3. Apply even and firm pressure in the appropriate direction (see next page for diagram).

CAUTION!

An insufficiently tightened horn, probe or tip will impede the transmission of ultrasonic energy and may cause damage to the generator circuitry or mating parts of the convertor and horn.

Warning: An improperly tightened horn or horn tip may heat up and fail prematurely. **NEVER** assemble or disassemble the probe by holding the convertor in a vise. Always use the tools provided with the unit and place a firm mat or towel underneath the convertor and horn to prevent slippage or damage. Avoid pressing the sides of a MICROTIP or Extender down into a counter top when tightening or removing, as this may damage the tip.

A loud, high piercing sound emanating from the horn or probe indicates that one of the components may be loose or possibly cracked. STOP processing immediately. Turn off the generator and check the tightness of the horn to the convertor, and the tip or probe to the horn if applicable. If the loud noise persists, contact MISONIX for assistance.

See diagram on next page

ATTACHMENT AND REMOVAL OF TIPS AND HORNS

HORN and TIP - Removal / Re-tipping



Horn Removal



Horn Tightening



Tip Removal



Tip Tightening



Microtip Removal



Microtip Tightening



Wrench Set

7. S3000 OPERATING INSTRUCTIONS

Review of Keys

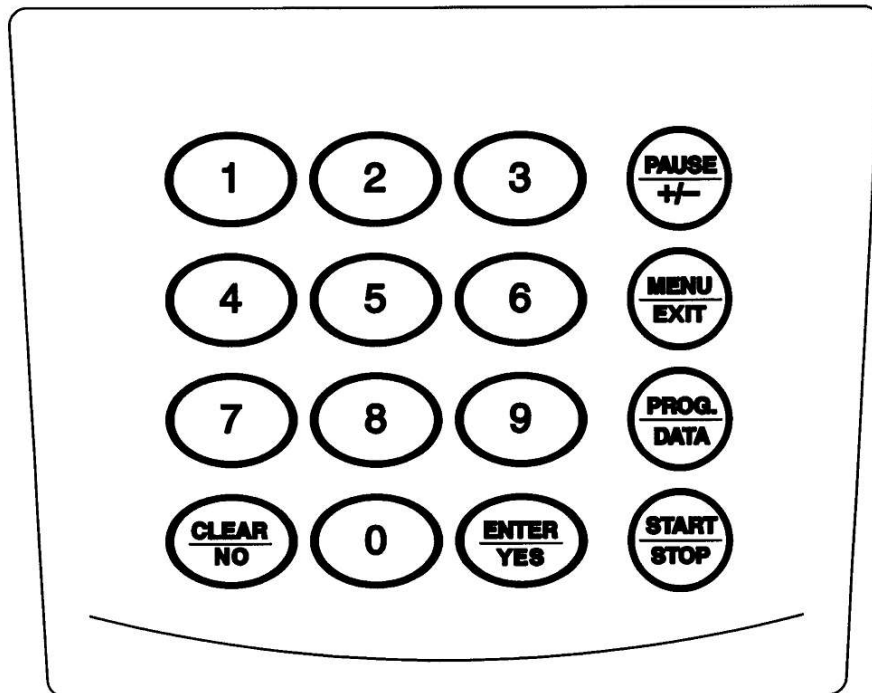

<u>Key</u>	<u>Action</u>
<u>START</u> <u>STOP</u>	Starts or Stops output in all modes of operation. Resets timer in timed mode.
<u>PROG</u> <u>DATA</u>	Initiates Timer and PULSAR™ entry program and displays entries on the LCD screen during run.
<u>ENTER</u> <u>YES</u>	Enters data during program mode or allows answering questions with a “YES” answer.
<u>CLEAR</u> <u>NO</u>	Clears previous or erroneous entries. Exits programming mode. Answers questions with a “NO” answer.
<u>MENU</u> <u>EXIT</u>	At the PROGRAM screens, allows access to other programmable parameters.
<u>PAUSE</u> <u>+/-</u>	Interrupts or Resumes processing cycle. Allows toggling between positive and negative temperature values when setting temperatures.
Numeric Keys	Allows entry of numeric data and selection of programmed memories.

OPERATION AND PROGRAMMING INFORMATION

Power-Up

At power-up, the following message will scroll onto the display:

```
SONICATOR 3000
MISONIX INCORPORATED
```

The above screen will stop scrolling, then, after a short time, the MicroTip question will appear. (At any time during the scrolling message, pressing any key will immediately display the MicroTip question).

Programming the Proper Tip

After the startup screen, the following question will appear on the display:

```
Are you using a
MicroTip (Y/N)?
```

The answer to this question sets up proper operating parameters for the horn that will be used. If using a MicroTip horn, answer "YES" to this question. If using any other type of horn, answer "NO".

Program Mode or Continuous Operation Selection

Next, the following two screens will alternate on the screen every three seconds:

```
Press PROG to Program
Timer and PULSAR or
```

```
Press START for
Continuous Operation
```

Pressing **START** will cause the unit to go into a Continuous mode of operation with the Power setting at 0.0. (See "Continuous Mode Operation" for the display that will appear). No processing will occur until the Power Select Knob is turned clockwise to a value greater than 0.0. This mode allows the operator to start processing quickly without going to any of the programmed memory setups.

To program a setup or access a previously-programmed memory setup, press the **PROG** key on the keypad.

Programming Mode

When the Programming Mode is selected, the following five screens will cycle in succession, changing at three-second intervals:

```
00:00:00      Program 1
00:00.0      00:00.0
```

Shows currently-programmed timing information for Program 1 (Program 1 is the default).

```
No Temperature
Control Selected
```

This screen may be different depending on programmed temperature control parameters.

```
Output Level Set at 0.0
```

Shows the current program starting output power knob setting.

```
Press START to Run,
PROG to Program, ...
```

Indicates which keypad keys can be used.

```
Press MENU for Options,
1-9 for Other Programs.
```

Indicates additional keypad keys that can be used.

For the first screen above, the function of each of the timing values is printed on the display panel next to the associated value. The top-line timing value represents the programmed Process Time, the left bottom-line value represents the programmed Pulse-ON time, and right bottom-line value is the programmed Pulse-OFF time.

For the second screen above, if only monitoring temperature, with no temperature control, the following screen will appear instead:

```
Temperature
Monitoring
```

Also, for the second screen above, if temperature control is programmed, the following screen will appear instead:

```
Control Temperatures:
MAX=120°C      Cool=100°C
```

If no cooling temperature is programmed, "NONE" will appear in place of that temperature.

At this point, one of several things can be done (detailed information follows):

- 1) Press any of the nine numeric keys, [1] to [9], to access one of the nine stored Program setups.
- 2) Press **START** to begin running using the currently displayed Program information.
- 3) Press **MENU** to access other optional setup information.
- 4) Press **CLEAR** to return to the MicroTip question.
- 5) Press **PROG** to change any or all programmed information values for the current Program that are displayed.

1) Selecting a Programmed Memory Setup

There are nine possible program memories that store programmed setup information, and maintain those programmed parameters even after turning off the unit. Any one of those nine memory setups (Program numbers) can be accessed by pressing the associated numeric key, [1] to [9], on the keypad (i.e.: pressing the [5] key will bring up the programmed settings for Program 5). For all program memories, all timing parameters and output levels are factory programmed to zero, with no temperature control.

2) Running the Current Program

The Program that is currently displayed on the five alternating screens can be run by pressing the **START** key.

3) Accessing the MENU Options

By pressing the **MENU** key, options are shown to change the temperature units (degrees Celsius or Fahrenheit), and to select whether the knob value should be stored when processing is stopped.

4) Returning to the MicroTip Question

If it is necessary to change the answer to the MicroTip question, press **CLEAR** when the five screens are being displayed.

5) Programming a Memory Setup

Pressing the **PROG** key when the five screens are alternating will access the Programming Mode, in which any or all programmed values can be changed for the currently displayed Program.

NOTE: Any of the following screens that prompt for a settable parameter will always show the currently-programmed value, such that pressing **ENTER/YES** will skip to the next screen. After any value is changed AND **ENTER** is pressed to store that value, when the next screen appears, the **EXIT** key can be pressed to revert to the initial five screens. All parameters after the value that was changed will be retained in memory.

For example, a Program has the following parameters: Process Time = 00:10:00, Pulse-ON Time = 00:02.5, Pulse-OFF Time = 00:10.0, Initial Level = 4.0, and only using Temperature Monitoring (no temperature control). If it is desired to only change the Pulse-OFF time to 00:05.0, press **PROG** when the five screens are cycling, then press **ENTER** twice to bypass the Process Time and Pulse-ON time. Key-in [5][0] and press **ENTER**, then press **EXIT**. The Initial Power Level and temperature settings will remain as previously set.

Process Time Programming

The first display that appears will show the following screen, with the bottom line alternating at three-second intervals:

00:00:00 (hr:min:sec) Set Total Process Time

00:00:00 (hr:min:sec) Then Press ENTER

The actual value shown will depend on whether a value was previously programmed.

The "Process Time" is the total processing time desired. When running this Program, processing will continue until the Elapsed Time equals this programmed Process Time. Note that Elapsed Time is only counted when the horn is "ON", therefore, only "ON-Time" is counted. Pressing **CLEAR** at any time will zero the Process Time value. Setting this value to 00:00:00 will allow the unit to run "forever" with no automatic shutdown (see "Elapsed Time Counter"). The maximum value allowed is 99:59:59. When finished keying in the desired value, press **ENTER**.

Pulse-ON Time Programming

After entering the desired Process Time, the next screen prompts for the Pulse-ON time, with the top line alternating at three-second intervals:

```
Set Pulse "ON" Time
00:00.0 (min:sec.tenths)
```

```
Then Press ENTER
00:00.0 (min:sec.tenths)
```

If processing continuously, (no pulsing), enter 00:00.0 for the Pulse-ON time and press **ENTER**. This will also skip asking for a Pulse-OFF time.

The minimum Pulse-ON time is 0.5 seconds. Key-in any value from 00:00.5 to 59:59.9, or 00:00.0, then press **ENTER**.

Pulse-OFF Time Programming

After entering the desired Pulse-ON Time, the next screen prompts for the Pulse-OFF time (if 00:00.0 has not been entered for the ON time), with the top line alternating at three-second intervals:

```
Set Pulse "OFF" Time
(min:sec.tenths) 00:00.0
```

```
Then Press ENTER
(min:sec.tenths) 00:00.0
```

Key-in any value from 00:00.5 to 59:59.9, or 00:00.0, then press **ENTER**.

NOTE: Entering 00:00.0 for the Pulse-OFF time will assume that continuous mode is desired (no OFF time) and the ON-Time will automatically be zeroed, which also indicates Continuous Operation.

Setting Initial Output Level (Knob Setting)

After programming the ON/OFF times, the following screen will prompt the operator to obtain an initial Power Knob setting:

```
Set Initial Output Level
(0.0-10.0): 0.0
```

Key-in a value from 0.0 to 10.0 (in 0.5 increments only), then press **ENTER**. This will be the knob setting when **START** is pressed to begin processing. If set at 0.0, when **START** is later pressed to begin processing, no processing will occur until the knob is turned clockwise to a value greater than 0.0.

Programming Temperature Monitoring

The next question asked after setting the initial knob setting is as follows:

```
Temperature Monitoring
(Y/N)?
```

If a shutdown temperature or controlled-device temperature will be used, or if the temperature will be displayed with no temperature control, answer **YES** to this question. If the temperature probe will not be used, answer **NO** to this question. Pressing **NO** will revert the display to the initial five-screens for the Programming Mode (i.e.: no further programming information is required).

Programming Temperature Control

If **YES** is pressed for the Temperature Monitoring question, the next question asked is:

```
Temperature Control
(Y/N)?
```

Answer **YES** if a maximum shutdown temperature or external control temperature will be used. Answer **NO** if the temperature will be shown on the display while processing, but with no temperature control. Answering **NO** will revert the display to the initial five-screens for the Programming Mode. A maximum shutdown temperature **MUST** be entered if external device control will be used.

If **YES** is pressed, the operator will be prompted to enter the temperature at which processing will stop:

```
Set MAX Temperature
For Shutdown: 0°C
```

Using the numeric keys, enter the desired maximum temperature for shutdown. The allowable temperature range is -50°C to $+121^{\circ}\text{C}$ (-46°F to $+250^{\circ}\text{F}$). The sign, "+" or "-", can be toggled by pressing the "+/-" key. After keying in the numbers, press **ENTER**.

Programming the Control of an External Device

After entering the maximum shutdown temperature, one final question will be asked:

```
Controlling an
External Device (Y/N)?
```

This question is asking whether ANY external device will be controlled by the temperature probe. Usually this will be a cooling device to keep the temperature of the sample below a given temperature, but any device, such as an alarm, may be controlled.

If **NO** is pressed, the screen will revert the display to the initial five-screens for the Programming Mode. If an external device will be controlled, press **YES** and the operator will be prompted as follows:

```
Set Temperature to
Activate Device: 0°C
```

Using the numeric keys, enter the desired temperature when the external device should be activated. The allowable temperature range is -50°C to $+121^{\circ}\text{C}$ (-46°F to $+250^{\circ}\text{F}$), but the temperature **MUST** be less than the previously-set maximum shutdown temperature. The sign, "+" or "-", can be toggled by pressing the "+/-" key. After keying in the numbers, press **ENTER**. The screen will revert the display to the initial five-screens for the Programming Mode.

8. ACCESSORIES

CUP HORN

Installation

- 1) Install and hand tighten the cup horn onto the convertor.
- 2) Tighten the horn with the pin spanner wrenches.
- 3) Support the convertor and cup horn in the Sonabox™ Acoustic Enclosure or in a lab stand using two clamps on the **convertor case only**. DO NOT place a clamp at the base of the horn. This will dampen the transmission of ultrasonic energy from the convertor and will cause permanent damage to the generator (see diagram in section 6-2).
- 4) Install fittings (plugs and/or hose adapters) to inlet, outlet and overflow ports. Be careful not to over-tighten any attachments. At the bottom of the cup horn there are O-rings and a fitting port. Be careful not to over-tighten this fitting because it can cause O-ring leakage.
- 5) Water should be filled up to the midpoint between the top of the horn and top of the acrylic cup. Please allow room for displacement when sample is added.

For constant flow cooling, use hose adapters with soft tubing. Provide pinch clamps on the inlet and outlet tubes to control flow. An open-bath recirculating chiller is recommended for maximum cooling. The flow required is about 500 ml/min. Place a flat plate on the cup to avoid splashing if the coolant flow is turned too high.

For static cold water use, close off all three ports with the plugs provided and fill the cup. If sonication is brief, the heat generated in the cup is insignificant to affect the sample. If the water temperature rises, pour it out and refill the cup with cold water. To further lower the temperature, add crushed ice to the water. Immerse the sample vessel below the ice level so that sample vessel is fully exposed to the face of the horn, below the ice.

Another method of operation is to fit the outlet port with the hose adapter, soft tubing and a pinch clamp. Run the tubing, without bends or loops, directly to a drain. Add ice and water to the cup. After the ice melts, drain the cup and refill with ice and water. If the fittings leak, place TEFLON tape around the fitting threads. If coolant splashes into the shield, tip the shield edge to drain it.

For maximum transmission of acoustic energy into the sample vessel, use a cavitation-resistant fluid such as a water-glycol mixture, pure ethylene or propylene glycol. The sonication intensity will be greatly increased, in proportion to the glycol concentration.

Cup Horn Operation

Cup Horns are high intensity ultrasonic water baths that allow samples to be processed in completely closed containers (such as test tubes or vials). The ultrasonic probe never comes in contact with sample so that sample loss, escape and/or cross contamination cannot occur. Large Cup Horns allow for the simultaneous sonication of clusters of tube or vials providing for uniformity of processing. Cup Horns are ideal for sterile or pathogenic sample processing. Three different sizes are available.

Most laboratory grade plastic or borosilicate glass vessels that will fit into the cup are suitable for sonication. Polystyrene and polycarbonate are the best transmitters of acoustic energy. Polypropylene and polyethylene are too soft and may be ineffective. Glassware must be free of any scratches and fully annealed or it may over stress and crack.

Ultrasonic energy is radiated directly upward through the base of the vessel while transmission through the side is negligible. For this reason, flat-bottomed vessels are best and round bottomed are next best. Vessels should have thin, uniform bases, without any heavy edges or centers. Conical tubes should be tilted to expose maximum sample area to the horn. Samples should be wide and shallow, rather than tall and narrow.

Maintain a small clearance around the vessel to allow adequate coolant flow. **Suspend vessels at least 3 to 6 mm above the face of the horn.**

Energy transmission to the sample vessel can be determined easily by the pattern of sonication (cavitation bubbles or micro streaming) in the coolant. At low levels, the bubbles will usually appear as a dome of bubbles capping the coolant exit in the face of the horn. As the amplitude of the ultrasonic vibration (amplitude control knob setting) is increased, the bubble pattern will lift and become vertical diaphanous streams in the center of the cup, sometimes forming a spider-web effect.

Out Put Setting Parameters

When working with small samples there is a tendency to turn the Amplitude Control Knob setting too high. Doing so causes the ultrasonic energy to go around the vessel, not through it. The chart below is a good guide on selecting a power setting according to liquid sample volume. However, all samples differ and may require a slightly higher power setting according to their solid matter content and viscosity.

<u>Sample Volume</u>	<u>Power Setting</u>
100µl - 500µl	0 - 1
500µl - 2 ml	1 - 2
2 ml - 5 ml	2 - 4
5 ml - 20 ml	4 - 5
20 ml - 50 ml	5 - 7
50 ml - 200 ml	7 - 8

Cup Horn Maintenance

The cup is made of acrylic plastic and should be cleaned periodically with a mild detergent, not with abrasives or solvents. The horn is a tuned resonant body of titanium alloy. Do not attempt to resurface the horn if it shows erosion after extended use. Contact Misonix if

problems occur.

FLOCELL™

Flocells™ are used for the continuous processing of large volumes of sample material. The liquid is pumped into the Floccell™ through a carefully designed opening so that all of the sample passes through the cavitation field and receives maximum, uniform sonication. The annulus and orifice sizes are variable to accommodate differing viscosity and flow rate. Flocells™ are available that can process material at rates of 10 gallons per minute. Materials of construction vary with applications.

Transparent Polycarbonate Model (Part # 800A)

This model permits observation of the sonication process. The material of the body tube is resistant to most dilute acids and bases, oils, aliphatic hydrocarbons, ethers and alcohols. It may be attacked by strong alkalis, aromatic or halogenated hydrocarbons, or low molecular weight aldehydes. DO NOT EXCEED 50 psig PRESSURE or operate at full power on the Sonicator® amplitude setting, as this will damage the Floccell™.

Stainless Steel Model (Part # 800B)

The material of the body tube is resistant to most dilute acids and bases, oils, aliphatic hydrocarbons, ethers and alcohols. Strong acids can attack it. DO NOT EXCEED 100 psig PRESSURE or operate at full power on the Sonicator® amplitude setting.

The following information applies to both Models 800A & 800B.

1. Three ¼" NPT hose fittings and three ¼" NPT plugs are supplied.
2. Do not use the two body ports as both inlet and outlet.
3. Flow must be directed through the orifice. Select the appropriate size orifice and install it into the Floccell with a # -014 size O-ring in the orifice holder.
4. Assemble the orifice with the stepped side away from the holder, projecting through the knurled orifice retainer ring. Hand tighten retainer ring onto orifice holder.
5. Assemble a -026 size O-ring onto the holder and wet the O-ring and the mating surface on the inside of the Floccell body.
6. Use care in assembling the holder to the body to prevent stripping the first threads or cutting the -026 size O-ring.
7. Similarly, wet the -220 size O-ring in the other end of the body and the mating surface of the disruptor horn and fit the body over the disruptor horn.
8. Screw the Floccell body around the disruptor horn until the horn contacts the oriface plate and then back it off 3 turns.
9. The Floccell should not be tightened on the horn or it will dampen the ultrasonic vibrations.
10. Adjust the sonication annulus by screwing the holder in or out the appropriate distance from the radiating face on the tip of the horn.
11. Install inlet fittings into orifice holder and outlet and overflow fittings into Floccell body.
12. Connect soft plastic inlet and outlet tubing to the fittings provided, with valves as required.
13. Valves should be installed at the outer ends of the tubing to minimize the weight hanging from the horn.
14. Test the completed assembly for leakage before pressurizing.

Flow can be in either direction if only one inlet is used. It may be more advantageous to direct flow upwards through the orifice holder and out through the body fitting. Flow must be from the body toward the orifice holder if two inlets are used.

Orifice retainer and holder are stainless steel and have very fine threads shipped with a light film of machine oil to prevent galling. If the oil film is removed with the use of solvents or any other means, apply molybdenum disulfide, powdered Teflon, graphite or other appropriate lubricant.

Stainless Steel Model (Part # 800C)

1. Clean cell and all metallic parts with appropriate solution.
2. Install the #228 size O-ring on to the horn.
3. Attach horn to the convertor and tighten using pin spanner wrenches as described in sections 6-3 and 6-4.
4. Push horn into the end of the Floccell with the stepped shoulder, until fully seated on shoulder.
5. Place one 3" gasket on upper flange.
6. Place each half of split ring over gasket, checking the seating of rings on gasket.
7. Place one of the 3" clamps around upper flange and split ring and hand tighten.
8. Thread flow tube into liquid inlet and tighten with a suitable wrench.
9. Place the second 3" gasket on the liquid inlet and place the inlet and gasket against the Floccell bottom flange cell, checking the seating of gasket.
10. Place the second 3" clamp around lower flange and inlet plate and hand tighten.
11. Connect cell to plumbing via 2" union. Connect vent line via 2" union.
12. Connect convertor cable to convertor and generator.
13. If cell/convertor assembly cannot be supported by the inlet/outlet plumbing, a clamp around the cell may be used. If clamping both cell and convertor, DO NOT clamp in a manner that might cause misalignment on axial centerline of the Floccell and convertor.

Stainless Steel Model (Part # 800D)

Special instructions are included with the 800D Floccell™.

MICROTIP™

Part Numbers: (418, 419, 419A, 419B)

MICROTIPS™ attach directly to the end of the ½" diameter tapered horn in place of the flat tip. The MICROTIP™ Probes are tapered down to a narrow point and serve as a third stage of acoustic amplification. They are used to process small sample volumes ranging from 0.2 - 50 ml.

The MICROTIP™ is a precision instrument and is designed to give extreme output intensity. To obtain the maximum life from this accessory, the following precautions must be observed.

1. Do not permit the MICROTIP™ to fall or drop on a hard surface or to bear against the worktable during installation or removal.
2. The MICROTIP™ should never be operated in air.
3. Always immerse the MICROTIP™ in the sample liquid before turning on the instrument. Immersing an energized MICROTIP™ into the sample may cause splashing, aerosoling or foaming.
4. If the material being treated aerosols or foams, the generator should be turned off immediately as this is equivalent to operating the MICROTIP™ in air and will cause it to heat up and possibly fail.
5. The MICROTIP™ must not be allowed to touch the rim or side of the processing vessel, especially close to the MICROTIP™ end (the radiating surface).

WARNING!!

The MICROTIP™ operates close to the stress limits of titanium and any of the above mentioned conditions can introduce a microscopic crack in the tip or cause it to break. The output intensity (or amplitude) of the MICROTIP™ probe is considerably larger than that of the standard ½" horn. All cautions and warnings must be observed at all times.

STEPPED MICROTIP™

Part Number: (420)

The stepped MICROTIP™ consists of an upper section and a lower section. The upper section is used in place of the standard horn, and the lower section attaches directly into the upper section. The lower section has 3 steps that reduce the probes diameter from ½" to 1/8". The Stepped MICROTIP™ is used in place of a tapered MICROTIP™ when a longer reach and narrower profile are required, such as when processing samples in long, narrow test tubes (e.g. 12mm x 75mm).

EXTENDER TIP

Half-Wave and Full-Wave Extenders are used to extend the length of a horn and provide longer reach when needed. Extenders attach directly to the end of any tapped horn of equal tip diameter. They are cylindrical (not tapered or stepped), and are available in lengths of 5" or 10".

When Extender Tips are used for long-duration processing at high output settings, they may develop considerable heat. Do not allow them to exceed 140°F (60°C) (observe MICROTIP™ precautions).

SAPPHIRE TIPPED HORN

1. Sapphire tips are thin discs of pure, water clear, boule-grown, synthetic sapphire, bonded with an extremely high-shear epoxy to the radiating face of solid ultrasonic horns. Sapphire discs can not be used on removable flat tips because the wrenching forces would be transmitted to the disc and cause fracture. Sapphire discs are only available for horns ½" and larger (12.7 mm) in radiating face diameter.
2. Sapphire disc tips are very hard, with a rating of 9.0 on the Mohs scale (where diamond is 10). However, they are also easily fractured by mechanical shock or bending. Therefore, avoid any contact between the tip and any solid object, especially when the horn is energized.
3. The thin layer of epoxy holding the sapphire disc to the end of the horn is subject to cavitation erosion and leaching under strong chemical attack. Always check the condition of the bond. Visible loss of epoxy under the tip will result in eventual failure of the disc.
4. The sapphire tip generates cavitation in liquids exactly in the same manner as the titanium tips. The sapphire disc will normally last approximately 10 times longer than the regular titanium tip. Erosion appears as a matte finish on the radiating face. Eroded discs can NOT be refinished or polished.
5. Horns with broken or chipped discs should never be used. Erosion could occur on the exposed face of the horn and render it unsalvageable.
6. Cracked, broken or eroded discs can be removed from used horns and replaced at the factory. Contact MISONIX or local representative for current replacement information.
7. Be sure to store sapphire tipped horns in a safe place and well protected from impact. Ambient temperatures and humidity will not damage the disc or epoxy.

SONABOX

Before unpacking or assembling, please READ INSTRUCTIONS carefully. See page 8-8 for diagram.

Unpack by grasping the Enclosure body to lift from carton. DO NOT lift by latch assembly (door handle). Open SONABOX by lifting latch handle to the horizontal position and turning handle 90° in either direction. Remove and unwrap two Z-shaped legs with two rubber feet attached to each leg.

For Standard Horn or Microtip Assembly

Remove the four screws holding the Converter Cup to the Sonabox, invert cup with cylindrical sleeve facing upward, and reinstall screws as shown in the diagram on page 9-8.

For Cup Horns

Remove the four screws at the corners of Sonabox. Place Z-shaped legs on Sonabox and reinstall screws. To fit coolant tubing to cup horn, remove two screws from Z-strip, reverse Z-strip to uncover three holes, and reinstall screws. Pass coolant tubing through holes. Invert Enclosure.

If the Acoustic Enclosure is to be used exclusively with the cup horn, the latch handle may be reversed to close downward. Remove inner nut that secures pawl. DO NOT allow adjusting (outer) nut to rotate. Remove pawl, rotate it 180° on shaft, reinstall pawl and nut, and tighten nut.

DUAL HORN

The Dual Horn accessory allows a single Sonicator® to process two samples simultaneously. Power is delivered to two ¾" diameter solid stepped extenders, which vibrate at the same intensity as a single ¾" horn. EPA specifications, such as in Method SW846-3550, are met for power output, probe size and intensity.

MICROPLATE HORN

The Microplate Horn is designed to provide ultrasonic energy to all the wells in a single polystyrene or polypropylene microplate. It attaches directly to the converter in place of the standard horn. There is a circular radiating surface with an attached clear acrylic sleeve. The sleeve of the Microplate Horn is filled with water (or other liquid) and microplates are placed inside. The Microplate Horn works in principle like a Cup Horn, only it is larger and custom designed for microplates. *Detailed instructions are included with the Microplate Horn.*

SONABOX ACOUSTIC ENCLOSURE

Unpack by grabbing the enclosure body not the door handle. Open the door by turning the latch 90° in either direction.

Standard Horn or Microtip assembly: see figure 1A

Remove the four screws from convertor next, invert neck with cylindrical sleeve outward and reinstall screws.

Cup Horns: see figure 1B

Remove the four screws at corners of box. Place Z-shaped legs on box as shown and replace screws. If fitting coolant tubing to cup horn, remove two screws from Z-strip, reverse Z-strip to uncover three holes and replace screws. Pass coolant tubing through holes. Invert Sonabox.

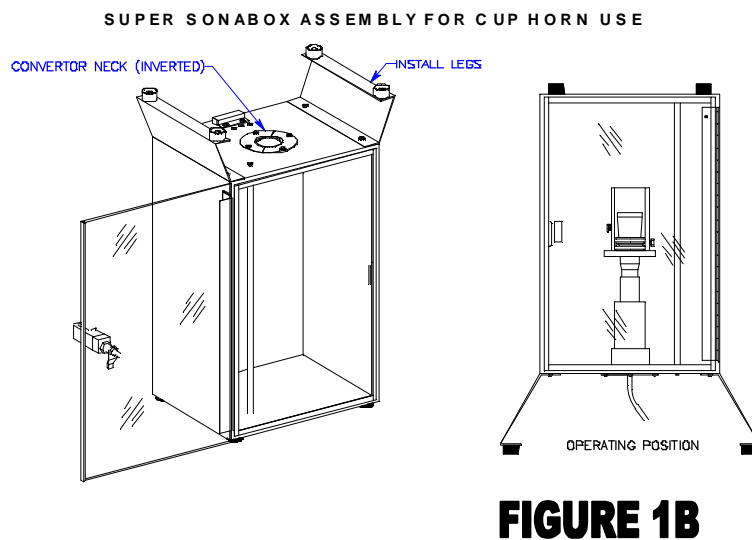
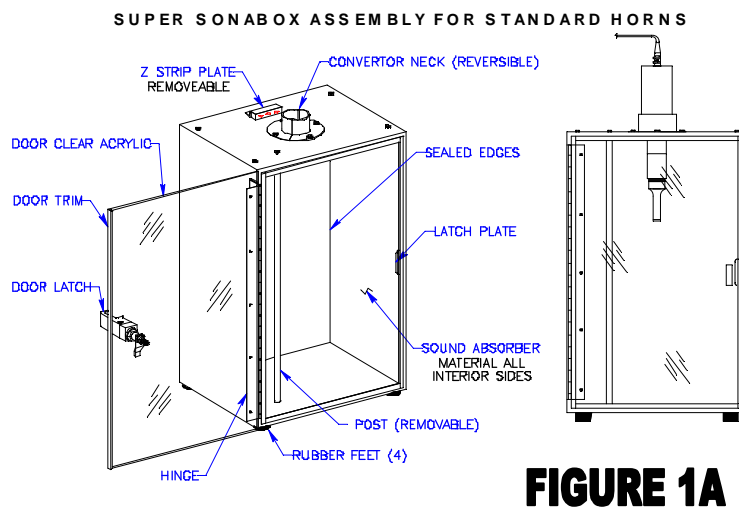

9. TROUBLESHOOTING

WARNING: To avoid electric shock, do not remove the cover from the Generator. There are no user-serviceable parts inside this device.

Overload Indicator Instructions

The Sonicator[®] 3000 generator is designed to deliver high power to the convertor/horn assembly on a continuous basis. However, under certain load conditions, the amount of power supplied might endanger the generator circuitry to the point of failure.

In order to prevent equipment failure, an overload protection feature has been built into the S3000 generator. When the output power exceeds design specifications, the output will be disabled. On the S3000, the following prompt will appear on the LCD display: "OVERLOAD! Press CLEAR to Reset". Also, the alarm will beep, and the power knob display will flash showing "888". When an overload occurs, proceed with steps 1 - 6 below:

1. Press **CLEAR**, then shut the unit off using main the power switch.
2. Check all electrical connections.
3. Eliminate contact between horn and sample. For flow cell applications, reduce internal pressure if necessary.
4. Check tightness of horns and/or tips. Remove tips and clean threads and mating surfaces if necessary.
5. Check horn for cracks or excessive tip erosion.
6. If all above fails to rectify problem, consult Misonix, Inc. Customer Service Department.

Troubleshooting Guide

SYMPTOM	POSSIBLE CAUSE	REMEDIAL ACTION
System does not turn ON	Power Cord not connected	Check Power Cord
System does not turn ON	Power Outlet off	Check wall socket for voltage
System does not turn ON	Blown line fuse(s)	Check & Replace fuse(s) if necessary
System is on, but there is no output	Convertor and/or cable disconnected	Check all electrical connections with power turned off.
System is on and properly connected, but there is no output	Electronic component failure	Send Unit in for service
When using the temperature probe, the unit goes into temperature shutdown immediately after pressing START	Maximum shutdown temperature is set lower than the measured probe temperature, or the probe is not installed properly or is defective.	Program a higher maximum shutdown temperature. Program the temperature probe for temperature monitoring only to verify the reading of the probe.

10. **MAINTENANCE**

It is recommended to periodically inspect the unit, both visually and physically, to insure optimum and safe performance. This inspection should be scheduled as a routine maintenance procedure, done with the Sonicator® power switch in the OFF position, and with the unit unplugged from the AC power source.

Long exposure to acids or caustics results in corrosion of metal parts or components. Check the generator, convertor, and cables periodically for any signs of rust or discoloration. If discoloration is found, move the Sonicator® away from the source of the contaminant.

Examine the condition of the high voltage cable that attaches the convertor to the generator. Inspect the wire insulation for damage, such as wear, burning from hot plate contact or breakage from extended use or rough handling.

Inspect the cable connectors by gently pulling on the wire while holding the metal portion of the connector. The cable connectors and rubber boot protectors at both ends of the cable should be tight to the wire, with no movement possible and no cracks or frayed ends visible. Do not subject the cable ends to severe bending loads while performing these tests. Order a replacement cable immediately if your cable does not pass the above inspection. Should the convertor/cable assembly be subjected to misuse, such as dropping or a severe pulling force on the wire itself, the cable must be inspected as above.

DO NOT USE A CABLE WITH BROKEN END CONNECTIONS, EXPOSED WIRES OR FRAYED INSULATION. HIGH VOLTAGE IS PRESENT IN THE CABLE AND MAY POSE A SHOCK HAZARD. DO NOT TOUCH THE CONVERTOR ASSEMBLY UNTIL THE POWER SWITCH OF THE GENERATOR IS OFF AND THE UNIT IS UNPLUGGED.

In general use, the cable assembly should not be used to carry the convertor or pull it toward the user. Make certain the cable always has slack and is never tensioned. If necessary, move the generator or convertor assembly closer to one another to accomplish this. If this is not possible, contact Misonix to obtain a longer cable.

Should the Sonicator® stop functioning, shut the unit off and inspect the cable as above **before** any other action is taken.

If the operator is in doubt as to the condition of the unit, call 800-645-9846 to speak with a customer service representative for prompt attention.

Cleaning Instructions

The generator and convertor may be cleaned using an acid-free cleaning solution (i.e. glass cleaner). Horns and probes should be cleaned using isopropyl alcohol.

Tip Care

The probe tip may be sterilized either by immersing in boiling water, autoclaving, or in a detergent bactericide and a disinfectant. **DO NOT AUTOCLAVE OR IMMERSER CONVERTOR AT ANY TIME.** Before each procedure place the probe tip in water or alcohol and turn the power on for a few seconds to remove residue. The tip also can be sterilized using alcohol with the power on. Alcohol is a volatile compound and proper handling precautions must be taken while sterilizing with alcohol.

The sides and end of the tip must **NEVER** be allowed to come in contact with anything but the solution. When using a microtip, the stress resulting at the point of contact with the vessel could cause the microtip to fracture. Standard probes may not fracture if they come in contact with the vessel, but can damage the vessel.

Touching the vessel wall with the tip will release tiny glass and titanium particles into the sample that may gray the solution. The particles will form a thin dark gray layer on centrifuging but usually have an insignificant effect chemically.

Proper care of the probe is essential for dependable service. The intense cavitation will, after a prolonged period, cause the tip to erode, and decrease the efficiency of the sonication process without showing up on the power monitor. The smoother and more polished the tip, the more power will be transmitted into the liquid. Any erosion of the probe tip will increase the rate of future erosion. For that reason, it is recommended that after every 5 or 6 hours of use, the tip be examined, and if necessary, polished with a fine emery cloth. Since the probe and tip are tuned to vibrate at a specific frequency, it is important that only the contaminated surface be removed. If tip or horn is excessively eroded, replace the tip or horn as in instructions on 6-4. When changing the tip, check for wear in all mating surfaces. If the horn itself is worn or damaged, replace the horn as well.

11. APPLICATIONS

Principles of Ultrasonics

The generator (power supply) converts conventional 50/60 Hz AC line power to 20kHz electrical energy that is fed to the convertor where it is transformed into mechanical vibration. The heart of the convertor is a piezoelectric crystal stack which, when subjected to an alternating voltage, expands and contracts.

The convertor vibrates in the longitudinal direction and transmits this motion to the horn tip immersed in the liquid solution. Cavitation results, in which microscopic vapor bubbles are formed momentarily and implode, causing powerful shock waves to radiate throughout the sample from the tip face. Horns and Microtip probes amplify the longitudinal vibration of the convertor; higher amplification (or gain) results in more intense cavitation action and greater disruption. The larger the tip of the probe, the larger the volume that can be processed but at a lesser intensity.

The convertor is tuned to vibrate at a fixed frequency of 20kHz. All horns and Microtip probes are resonant bodies, and are also tuned to vibrate at 20kHz. Intense cavitation after a prolonged period will cause the tip of the horns and Microtip probes to erode. Erosion will cause a slight variation in frequency.

The Sonicator[®] will break down cells, bacteria, spores or tissue. It can prepare an emulsion down to 1/100 of a micron, homogenize immiscible liquids, polymerize some materials, de-polymerize others, and accelerate chemical reactions. By virtue of this instrument, faster and more efficient extraction of serums, toxins, enzymes, and viruses from organic sources is also made possible. Cavitation breaks down cell structure rapidly, allowing the desired material to pass into the processing medium before the cell contents undergo any substantial chemical change. It also does an excellent job of degassing.

Processing Tissue

Whenever possible, the tissue should be diced very small to permit movement within the liquid. Freezing followed by powdering could also be used, if this procedure is not detrimental to the experiment.

Large samples should first be liquefied in a high-speed mechanical blender for about 10 seconds. If sub-cellular particles are desired intact, the amplitude control should be set low and the processing time increased.

Since the greatest concentration of energy is immediately below the probe, it is imperative that the sample is kept as close to the tip as possible. Liquids are easily processed because the free moving cells circulate repeatedly below the probe. Solid materials, however, have a tendency to be repelled by the ultrasonic action. To alleviate this problem, the vessel should be large enough to accommodate the probe, yet small enough to restrict sample movement.

If the probe has to come in contact with a solid sample, use a standard 3/4" (20mm) diameter stainless steel centrifuge tube cut to 3" (70mm) length. Do NOT use a glass tube.

Processing Difficult Cells

When processing difficult cells, the use of enzymes should be considered. Glusulase can be used with yeast, lysostaphin can be used with staphylococcus, collagenase can be used with skin and cartilage, and trypsin hyaluronidase can be used with liver and kidney.

Glass beads in the 10 to 50 micron size range can also be added to the liquid to expedite processing. When using glass beads, a good ratio is beads, liquid. Glass beads concentrate the energy released by the implosion and facilitate the crushing of cell walls. After processing, the glass will sink to the bottom of the vessel or can be centrifuged or filtered out.

Note: For further application information see section 15 (Literature Request).

12. TECHNIQUES

Probe Depth

Immerse the probe tip not less than 1 to 1-1/2 times the tip diameters into the solution, without touching the bottom. This depth rate applies to the " " horn; immersion depth can be less for larger horns and may have to be more for smaller probes used at higher intensity.

Foaming and Aerosoling

Insert the tip deep enough below the surface of the liquid to insure there is no aerosoling or foaming. Aerosoling and foaming generally occur when the tip is not immersed far enough into the solution. Lowering the power and increasing sonication time will usually reduce aerosoling; in severe cases, use an aerosol cap or sealed atmosphere treatment chamber. In organic materials, protein release from cell material acts like a wetting agent and tends to promote foaming. Lowering the tip in the solution, increasing power, and reducing solution temperature will normally prevent foaming. For severe foaming:

- Use a narrower processing vessel
- Use a vessel with an irregular inner surface
- Increase effective viscosity by concentration or by adding glass beads.

Once foaming occurs, shut off power or reduce it below cavitation level before proceeding. It maybe necessary to use a centrifuge or high vacuum to reduce tenacious foam. If foam persists, the sample may have to be discarded.

Viscosity Limitations

Viscous solutions and highly concentrated liquids can be difficult to sonicate. If the liquid is so thick that it will not pour or circulate easily, or if 25-micron glass powder will not settle to the bottom quickly, it is too thick and cannot be processed effectively.

Keeping Samples Cool

Intense ultrasonic processing causes the liquid temperature to elevate especially with small volumes. Since high temperature reduces cavitation, the liquid should be kept as cold as possible. This can be accomplished by immersing the sample vessel in an ice-salt-water-alcohol bath, or by using a water-jacketed processing vessel through which very cold water or alcohol is circulated. To minimize temperature elevation, use the PULSAR & Cycle Timer or pulse manually in short, quick bursts.

Free Radical Information

Trace free radicals produced by ultrasonics will usually have little or no enzyme activity. The free radicals may be H_2O_2 , O_3 as well as many other molecules and ions produced from air or water. If this kind of reaction is suspected, it can easily be avoided by using CO_2 or N_2 atmosphere. A CO_2 atmosphere is quickly obtained by placing a pellet of dry ice in the solution before processing and let it "bubble out". A CO_2 atmosphere stops luminescence in the cavitation bubble for the same reason it prevents it in a vacuum tube. It is this luminescence which causes the water and air molecules to break up producing the radicals. This CO_2 procedure, as simple as it is, again is ordinarily unnecessary.

13. WARRANTY

The generator and convertor of the Sonicator® 3000 Ultrasonic Liquid Processor device and accessory equipment manufactured by MISONIX, Incorporated are unconditionally warranted for a period of two years from the date of original delivery.

Horns, Tips and Microtip™ probes are warranted against defects in material and workmanship, under normal use in accordance with written instructions, for a period of two years from the date of original delivery.

The obligation of MISONIX Incorporated under this guarantee will be to make any repair at its plant in Farmingdale, New York, or at any of its designated service centers, without charge, including parts and labor, but not including shipping charges, necessitated by any defect in workmanship or material.

This guarantee is in lieu of any warranty of any kind or nature including fitness for any particular application under the Uniform Commercial Code or any other statute, regulation, court decision, or otherwise. MISONIX Incorporated shall not be responsible for any consequential damages.

This warranty shall not apply to any product or replacement part which has been subjected to any damage as a result of an accident or abuse, or that has not been used and maintained in accordance with the information contained in the literature accompanying the product or that has been modified, repaired or serviced by any person or company other than Misonix, Inc. or its authorized representative.

14. **RETURN OF EQUIPMENT**

All request for repairs and replacement parts should be directed to the Customer Service Department at Misonix, following the outlined procedure below.

1. Be prepared to provide the serial numbers of all applicable parts.
2. Call Customer Service (1-800-645-9846) to obtain a RMA (Return Material Authorization).
No returns are accepted without an RMA number.
3. When sending in equipment, always include the generator, convertor and all horns and probes. Equipment should always be sent in the original packaging.
4. Have your RMA number available when calling to check on returned items.

CAUTION!!

When original packaging is not available, be sure to wrap the convertor and generator separately in plastic bags, film, or other protective wrapping when using loose packing materials such as foam pellets, shredded paper, or excelsior. Remove MICROTIP probes or extenders and pack separately in same carton.

IMPORTANT NOTICE

BY RETURNING ANY MATERIAL TO MISONIX INC., THE CUSTOMER OR THE CUSTOMER'S AGENT THUS CERTIFIES THAT ANY AND ALL MATERIALS SO RETURNED ARE, OR HAVE BEEN RENDERED, FREE OF ANY HAZARDOUS OR NOXIOUS AND/OR INFECTIOUS MATTER OR RADIOACTIVE CONTAMINATION AND ARE SAFE FOR HANDLING UNDER NORMAL REPAIR SHOP CONDITIONS. DO NOT RETURN ANY MATERIAL, FOR, WHICH SUCH CERTIFICATION CAN NOT BE MADE WITHOUT PRIOR APPROVAL FROM MISONIX, INC.

The correct return address should read as follows:

Misonix Incorporated
RMA # _____
1938 New Highway
Farmingdale, NY 11735 (USA)
Attn: Repair Department

Misonix Incorporated can be contacted by the following:

Web Site: www.misonix.com
Telephone: 1-800-645-9846 or (631) 694-9555
Fax: (631) 694-9412

15. LITERATURE REQUEST

Available from Misonix is descriptive material on ultrasonic liquid processing. To order, place a check next to the title you wish to receive. (Quantity limit is one copy per title)

PUBLISHED PAPERS:

- [] RPT-I "Probe Ultrasonics: Increased Productivity and Accelerated Reactions in the Modern Laboratory", American Laboratory News
- [] RPT-II "New Methods in Ultrasonic Disruption", American Laboratory
- [] RPT-III "Application of an Ultrasonic Probe" (Ultrasonic Power vs. Intensity in Sonication), American Biotechnology Laboratory

BIBLIOGRAPHIES:

- [] BIB-1 Action of Ultrasonics on Living Tissue
- [] BIB-2 Ultrasonic Action on Proteins, Polysaccharides, Nucleic acids, and Lipoproteins
- [] BIB-3 Background Paper on Ultrasonic Dispersion
- [] BIB-4 Ultrasonic Emulsification in Biological Materials
- [] BIB-5 Action of Ultrasonics on Polymers - General Research
- [] BIB-6 Effect of Sonication on NMR Spectra of Biological Materials
- [] BIB-7 Ultrasonic Extraction of Biological Materials
- [] BIB-8 Application of Ultrasonics in Geology and Earth Sciences
- [] BIB-9 Ultrasound and Disinfection
- [] BIB-10 Ultrasonics and Liposomes
- [] BIB-11 Sonochemistry - Ultrasonic Cavitation and Chemical Reactions
- [] BIB-12 Suslick Bibliography on Sonochemistry
- [] BIB-13 Biological Research Update
- [] BIB-14 Ceramics and Soils Research Update
- [] BIB-15 Industrial Applications Update
- [] BIB-16 Food Technology Update

APPLICATION NOTES:

- [] AN-1 Breaking the Heat Barrier
- [] AN-2 Disrupting Tough Tissue
- [] AN-3 The Tissue Issue
- [] AN-4 Pitfalls
- [] AN-5 Disruption Techniques - Yeast - Chlorella
- [] AN-6 Cup Horn Sonication
- [] AN-7 Ultrasonic Degassing of Liquids
- [] AN-8 Reduce Cavitation Noise
- [] AN-9 Booster Horns
- [] AN-10 Continuous In-line Processing
- [] AN-11 Microplate Sonication
- [] AN-12 Shearing DNA/RNA
- [] AN-13 Ultrasonics and Fine Particles
- [] AN-14 Ultrasonic Probes in Emulsions and Fuel Research
- [] AN-15 Explosion Resistance and Isolation
- [] AN-16 Focused Ultrasonic Cleaning
- [] AN-17 Anti-Contamination
- [] AN-18 EPA Method SW846-3550
- [] AN-20 Dual Horn
- [] AN-21 Micro Cup Horn
- [] AN-22 Microtube Holders

TECHNICAL NOTES:

- [] TN-1 Amplitude Measurement
- [] TN-2 Extenders and Sapphire Tips
- [] TN-3 Extending Control Range
- [] TN-4 Microtips
- [] TN-5 Half-Wave Length Extender Tips
- [] TN-6 Flow Cells
- [] TN-7 Development of Protocols

TECHNICAL BULLETINS:

- [] TB-1 Ultrasound, Hearing and Health
- [] TB-3 Sifting Solids
- [] TB-4 Pulsed Sonication
- [] TB-5 ASTM Test Method G-32

Please call 1-800-645-9846 for literature requests.